

4X PENN ENGRG CLA-632-1
6-32 THREADED FASTENER

TOP VIEW

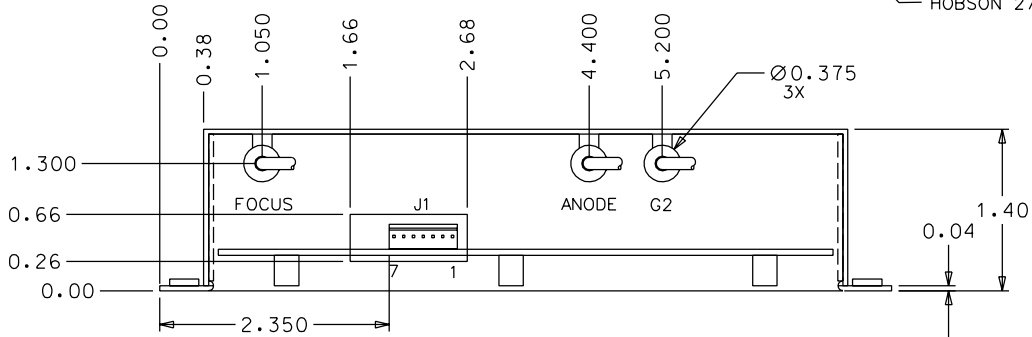
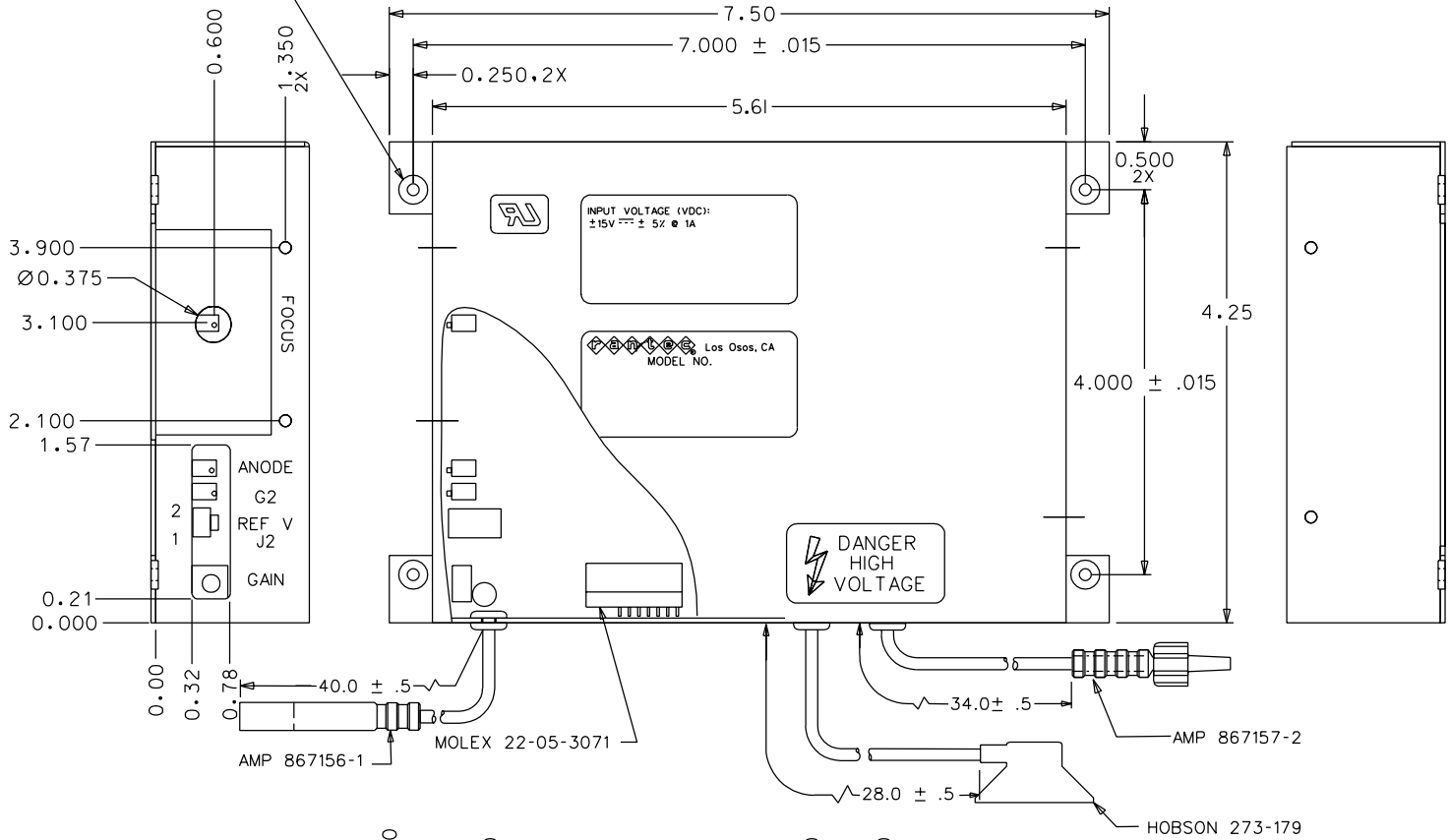

J1 OUTPUT

PIN #	FUNCTION
1	CATHODE
2	TTL , R/S
3	+15VDC INPUT
4	GND
5	-15VDC INPUT
6	DYN FOC IN
7	GND
8	N/C
9	G2 PROG INPUT

J2 OUTPUT

PIN #	FUNCTION
1	GND
2	TEST VOLTAGE

TYPICAL

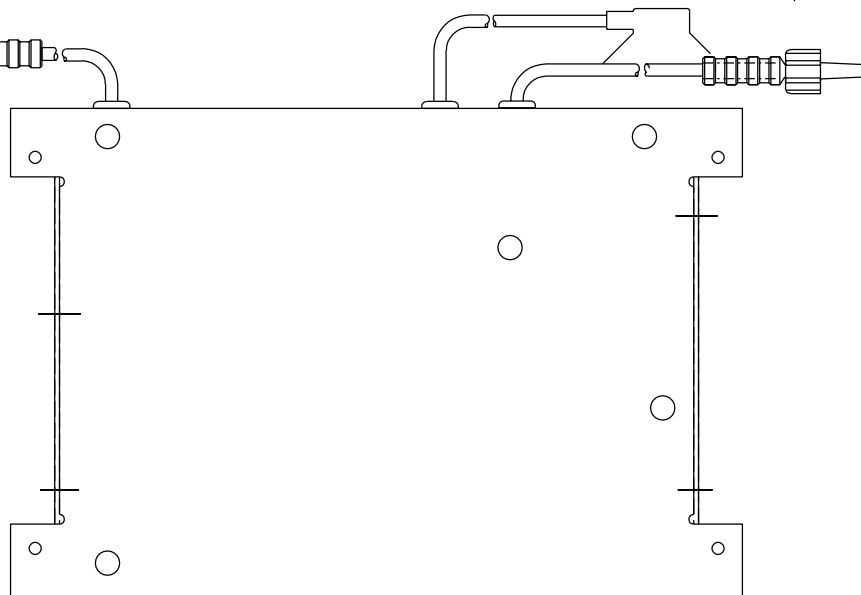

BOTTOM VIEW