

Power Solutions for Today's Military

Power Systems from **COTS+** Building Blocks

HDM-LLP

Single Output Series
270V input DC-DC Converter

- ◆ Up to 28W output
- ◆ Input to output isolation
- ◆ MIL-STD-704 compliant
- ◆ Secondary side control
- ◆ Fixed frequency operation
- ◆ External synchronization
- ◆ Remote sense compensation
- ◆ Shutdown control
- ◆ Mu metal shield for ultra-low radiated emissions
- ◆ Wide operating temperature range -55°C to $+95^{\circ}\text{C}$
- ◆ Ruggedized meets MIL-STD-810F
- ◆ NAVSO P-3641A design guideline
- ◆ Custom outputs available—consult Rantec for your unique requirements



Rantec's HDM series is the basic building block used to develop performance based "Power System Solutions" in today's military environment. Its compact size and high performance make it an ideal element for a distributed power system. The HDM-LLP uses secondary side controls for precision over-current/over-voltage protection set points, superior dynamic line/load response and regulation. Using fixed frequency switching technology, HDM series converters incorporate power MOSFETs, planar magnetics, and surface mount technology onto a metal clad PC board. The shielded module has excellent radiated emissions performance over a non-shielded module, translating to trouble-free system integration.

The System Designer's Choice

**Rantec Power Team Engineers
Offer Technical Assistance to:**
Evaluate Power System Requirements
Develop Power System Architecture
Reduce Time to Market



Rantec Power Systems Inc.

HDM-LLP

Single Output Series

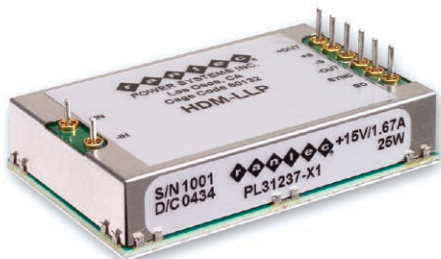

270V input DC-DC Converter

MODELS

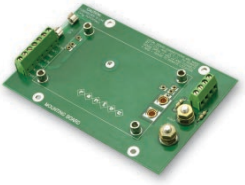

OUTPUT	PART NUMBER
3.3V@6A	HDM-3S6-3.3-01
5V@4.5A	HDM-3S6-5-01
12V@2A	HDM-3S6-12-01
15V@1.67A	HDM-3S6-15-01
28V@1A	HDM-3S6-28-01

HDM ACCESSORIES

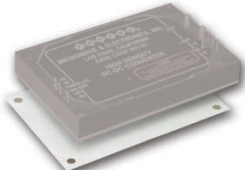
	HDM-MB Mounting Board for Evaluation & Prototypes
	HDM-SK Socket Kit
	HDM-TI Thermal Interface

INPUT

	MIN	TYP	MAX	UNITS	COMMENTS
Voltage	200	270	400	VDC	Steady State (Transients 180-450VDC)
Turn on time		100	400	mS	From Power Applied
			40	mS	From Enable
Switching Frequency		300		KHz	Fixed

ISOLATION

Input-Output	10M Ω min @ 1000VDC
Input-Case	
Output-Case	10M Ω min @ 100VDC

OUTPUT

	MIN	TYP	MAX	UNIT	COMMENTS
Set Point		0.5	1.0	\pm %	Full Load
Regulation - Line & Load		0.5	1.0	\pm %	Combined
Dynamic Load			5	\pm %	Deviation from steady state regulation (20-80%, 0.1A/ μ S Step) 250 μ S Recovery time to steady state range
Ripple		0.5	1.0	% p-p	20MHz BW
Turn on Overshoot			5	%	
Remote Sense Compensation			10	%	3.3 & 5V models
			1	V	12 – 28V models
Temp Coefficient			0.02	%/ $^{\circ}$ C	
On/Off Control					Open collector compatible, referenced to –Sense. Low turns unit off, open collector turns unit on. Consult factory for more information.

OUTPUT PROTECTION

Overvoltage	115	–	120	%	Non-Shutdown
Overcurrent	110	–	130	%	Auto Recovery

FREQUENCY SYNC

Frequency	330	350	370	KHz	See HDMA-102*
Width	50	100	150	nS	
Amplitude	1.0	1.5	2.0	V	

MECHANICAL

I/O Connection	Hand or wave solderable or insert into mated sockets. See Ap Notes HDMA-108 or HDMA-111
Weight	1.4 oz. max.
Construction	Surface mount, conformally coated. Mu-metal shield.

ENVIRONMENTAL

Cooling	Conductively cooled +95 $^{\circ}$ C max, baseplate
Operating Temperature	–55 $^{\circ}$ C to +95 $^{\circ}$ C, baseplate
Storage Temperature	–55 $^{\circ}$ C to +125 $^{\circ}$ C
EMI	Mu metal shield, electric & magnetic shielding
Humidity	MIL-STD-810F, Meth 507.4
Altitude	up to 70,000 ft
Shock	MIL-S-901D, Grade A, Class 1, Type A
Vibration	MIL-E-5400T, Curve IVa, 5 to 2KHz
Salt Fog	MIL-STD-810F, Method 509.4
MTBF	1,551,383 hours @ 55 $^{\circ}$ C baseplate (demonstrated, ground benign)

*Consult factory for application notes (also available online at www.rantec.com)



The System Designer's Choice

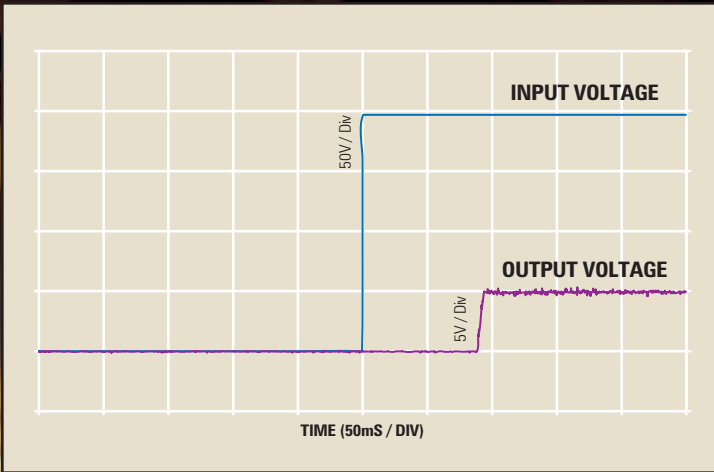

TURN-ON TIME
5V, from voltage applied

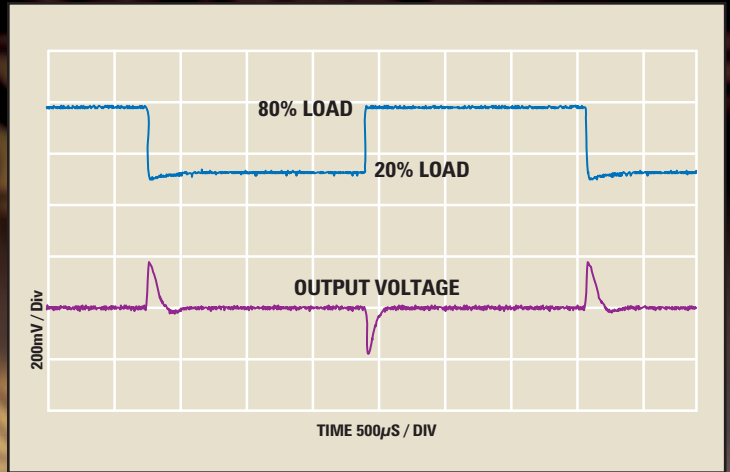

DYNAMIC LOAD RESPONSE
12V at 2A, 20-80% load step at 0.1A/µs

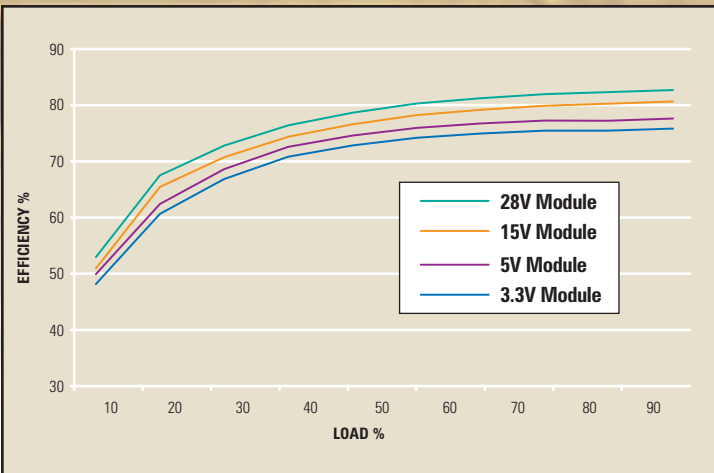

EFFICIENCY VS LOAD
Nominal Line, Ambient Temperature

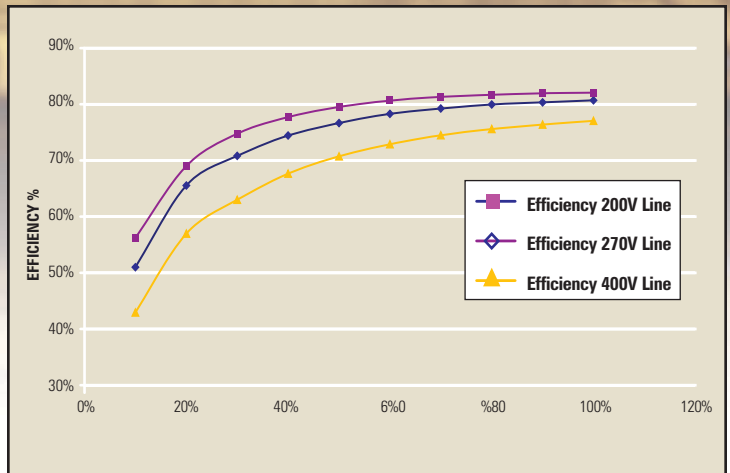

EFFICIENCY VS LINE
HDM-LLP, 12V

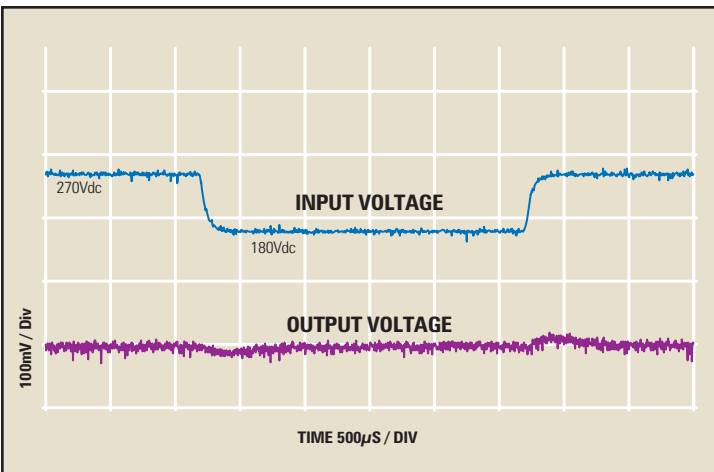

TRANSIENT LINE
Input 270 to 180VDC, Output 12VDC

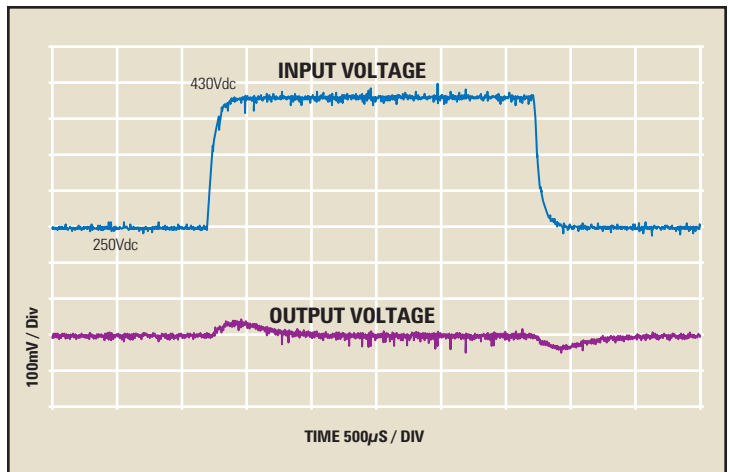

TRANSIENT LINE
Input 250 to 430VDC, Output 12VDC

HDM-LLP

Single Output Series
270V input DC-DC Converter

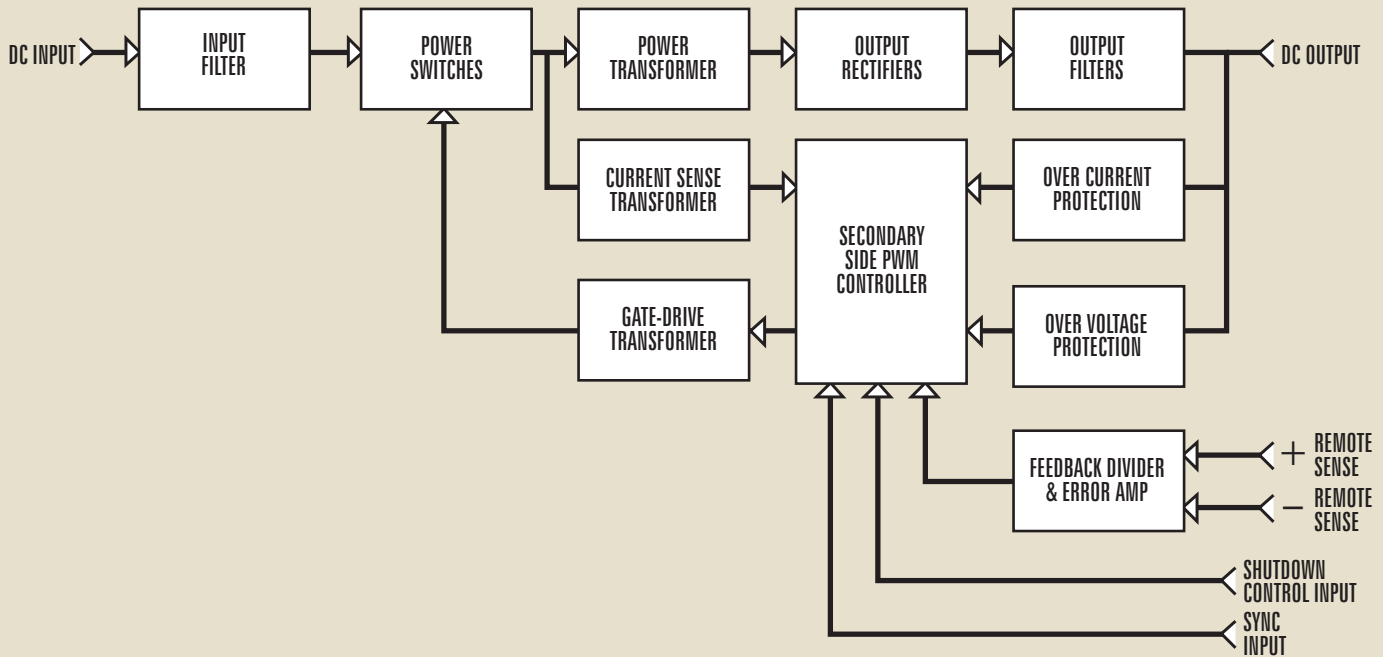

FUNCTIONAL BLOCK DIAGRAM

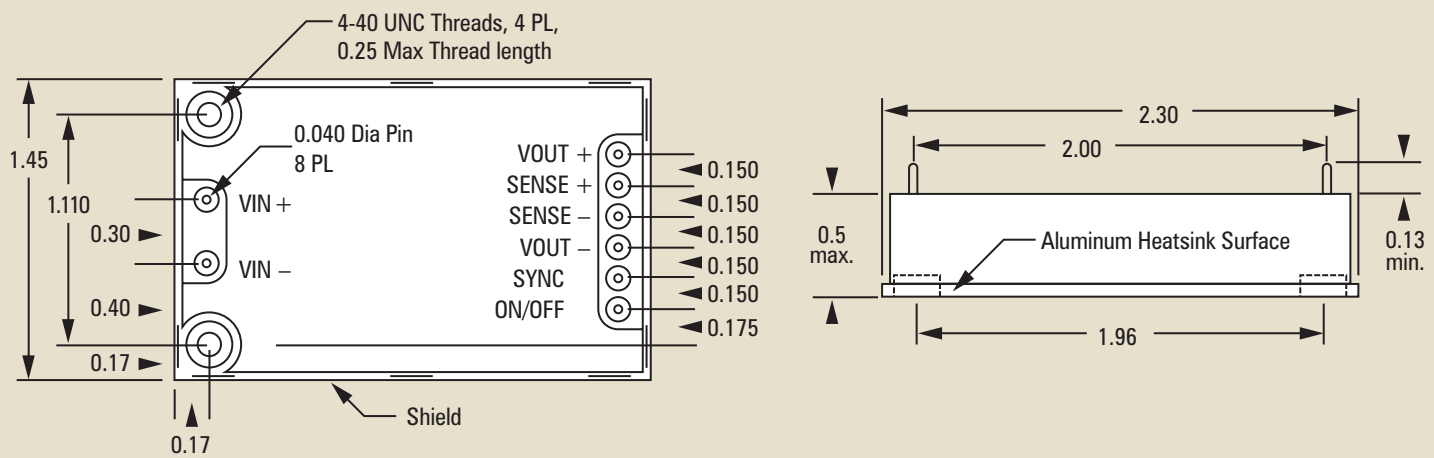

OUTLINE & MOUNTING DIAGRAM
Dimensions in inches, for reference only

Specifications subject to change without notice. ©2008 Rantec Power Systems Inc. All rights reserved. HDM-LLP REV 080619

1173 LOS OLIVOS AVE
LOS OSOS CA 93402
FAX 805 596 6006
powersys@rantec.com
www.rantec.com
805-596-6000



Rantec Power Systems Inc.